



5500 Series Washdown Fan Forced Unit Heater with bracket H5520/HMK, H5550/HMK

Data Sheet

General Characteristics 5500 Series Washdown Fan Forced Unit Heater with bracket H5520/HMK, H5550/HMK

Heavy-duty 304 16 gauge stainless steel shroud.
316 stainless construction available.
Nema 4x non-metallic control panel.
24-Volt control.
3-position switch (off-heat-fan).
Capillary thermostat with stainless steel sensor.
Automatic reset thermal cutout.
Totally enclosed U.L. listed motor.
Pilot light (power on indicator).
Stainless steel finned tubular element. Constructed of 304 or 316 stainless rod and fins.
Control panel on bottom of unit for ease of installation and service
Disconnect switch with enclosure door interlock.
Front grill rotates to direct airflow.
Single-point power connection.
Fan Blade Aluminum.
Epoxy painted cold roll steel model available, consult factory.
Meets all U.L., NEC, and OSHA requirements (when installed as directed).
Corrosion-resistant in high humidity and water-saturated areas (for areas where corrosion resistance is needed in non-explosive areas, contact factory for heater applications and optional materials).
Includes Mounting Bracket Kits
Made in U.S.A.

Product Applications 5500 Series Washdown Fan Forced Unit Heater with bracket H5520/HMK, H5550/HMK

Recommended for all industrial and commercial.
Used in dirty or dusty industrial areas in non-hazardous locations.
Also used in areas that may be high in humidity or water saturated.
For indoor and outdoor use.

Warranties 5500 Series Washdown Fan Forced Unit Heater with bracket H5520/HMK, H5550/HMK

Manufacturer's Limited Warranty: 1 Year.



The Washdown Series unit heaters are electric unit heaters constructed for use in areas that require washing or hosing of equipment due to dirty or dusty industrial environments in non-hazardous locations. The totally enclosed water-tight construction made with corrosion-resistant material make this series ideal for industrial heating applications. The Washdown Series is constructed with all built-in controls and safety temperature controls wired in a non-metallic Nema 4x control panel with single-point power connections.



Specific Characteristics 5500 Series Washdown Fan Forced Unit Heater with bracket H5520/HMK, H5550/HMK.

Item #	Watts	BTU's	Volts	PH	Amps	Temp Rise (°F)	Air throw	CFM	Included Components		Weight and Dimensions With Packaging (CM)	
									Bracket	MFG Model number	Lbs	W,H,D
USWHB-001	3.3	11200	208	1	15.9	26	20'	400	si	H5520/HMK	58	14,22,19
USWHB-002	3.3	11200	208	3	9.2	26	20'	400	si	H5520/HMK	58	14,22,19
USWHB-003	3.3	11200	240	1	13.7	26	20'	400	si	H5520/HMK	58	14,22,19
USWHB-004	3.3	11200	240	3	7.9	26	20'	400	si	H5520/HMK	58	14,22,19
USWHB-005	3.3	11200	277	1	11.9	26	20'	400	si	H5520/HMK	58	14,22,19
USWHB-006	3.3	11200	480	3	4	26	20'	400	si	H5520/HMK	58	14,22,19
USWHB-007	5	17100	208	1	24.1	40	20'	400	si	H5520/HMK	58	14,22,19
USWHB-008	5	17100	208	3	13.9	40	20'	400	si	H5520/HMK	58	14,22,19
USWHB-009	5	17100	240	1	20.8	40	20'	400	si	H5520/HMK	58	14,22,19
USWHB-010	5	17100	240	3	12.1	40	20'	400	si	H5520/HMK	58	14,22,19
USWHB-011	5	17100	277	1	18.1	40	20'	400	si	H5520/HMK	58	14,22,19
USWHB-012	5	17100	480	3	6.1	40	20'	400	si	H5520/HMK	58	14,22,19
USWHB-013	7.5	25600	208	1	36.1	60	20'	400	si	H5520/HMK	58	14,22,19
USWHB-014	7.5	25600	208	3	20.8	60	20'	400	si	H5520/HMK	58	14,22,19
USWHB-015	7.5	25600	240	1	31.3	60	20'	400	si	H5520/HMK	58	14,22,19
USWHB-016	7.5	25600	240	3	13.1	60	20'	400	si	H5520/HMK	58	14,22,19
USWHB-017	7.5	25600	277	1	27.1	60	20'	400	si	H5520/HMK	58	14,22,19
USWHB-018	7.5	25600	480	3	9.1	60	20'	400	si	H5520/HMK	58	14,22,19
USWHB-019	10	34130	208	1	47.8	45	20'	700	si	H5520/HMK	64	16,24,21
USWHB-020	10	34130	208	3	27.7	45	28'	700	si	H5520/HMK	64	16,24,21
USWHB-021	10	34130	240	1	41.2	45	28'	700	si	H5520/HMK	64	16,24,21
USWHB-022	10	34130	240	3	21.1	45	28'	700	si	H5520/HMK	64	16,24,21
USWHB-023	10	34130	277	1	36.1	45	28'	700	si	H5520/HMK	64	16,24,21
USWHB-024	10	34130	480	3	12.1	45	28'	700	si	H5520/HMK	64	16,24,21
USWHB-025	15	51200	208	1	72.1	68	28'	700	si	H5520/HMK	64	16,24,21
USWHB-026	15	51200	208	3	41.7	68	28'	700	si	H5520/HMK	64	16,24,21
USWHB-027	15	51200	240	1	62.5	68	28'	700	si	H5520/HMK	64	16,24,21
USWHB-028	15	51200	240	3	36.1	68	28'	700	si	H5520/HMK	64	16,24,21
USWHB-029	15	51200	480	3	18.1	68	28'	700	si	H5520/HMK	64	16,24,21
USWHB-030	20	68260	208	3	55.6	45	35'	1400	si	H5550/HMK	92	18,31,29
USWHB-031	20	68260	240	3	48.2	45	35'	1400	si	H5550/HMK	92	18,31,29
USWHB-032	20	68260	480	3	24.1	45	35'	1400	si	H5550/HMK	92	18,31,29
USWHB-033	25	85325	208	3	69.5	56	35'	1400	si	H5550/HMK	92	18,31,29
USWHB-034	25	85325	240	3	60.2	56	35'	1400	si	H5550/HMK	92	18,31,29
USWHB-035	25	85325	480	3	30.1	56	35'	1400	si	H5550/HMK	92	18,31,29
USWHB-036	30	102390	208	3	83.4	68	35'	1400	si	H5550/HMK	92	18,31,29
USWHB-037	30	102390	240	3	72.3	68	35'	1400	si	H5550/HMK	92	18,31,29
USWHB-038	30	102390	480	3	36.1	68	35'	1400	si	H5550/HMK	92	18,31,29
USWHB-039	40	136520	480	3	48.2	70	42'	1800	si	H5550/HMK	126	20,33,33
USWHB-040	48	163824	480	3	57.8	84	42'	1800	si	H5550/HMK	126	20,33,33

MFG Model number	Description Bracket
H5520/HMK	Simple and economical if adequate overhead structure exists. Requires 1/2" pipe, cut and threaded (not supplied). 3.3-15KW.
H5550/HMK	Simple and economical if adequate overhead structure exists. Requires 1/2" pipe, cut and threaded (not supplied). 20-48KW.



Dimensions (in) 5500 Series Washdown Fan Forced Unit Heater with bracket H5520/HMK, H5550/HMK.

Item #	A	B	C	D	E	F	G	H
USWHB-001 a USWHB-018	12	18	19.75	15.25	16.25	6ft	8	6
USWHB-019 a USWHB-029	14	19	21.75	15.25	18	6ft	8	6
USWHB-030 a USWHB-038	16	27	28.75	19.50	17.50	6ft	15.50	4.50
USWHB-039 a USWHB-040	18	31	30.75	19.50	19.50	6ft	21.75	2.75

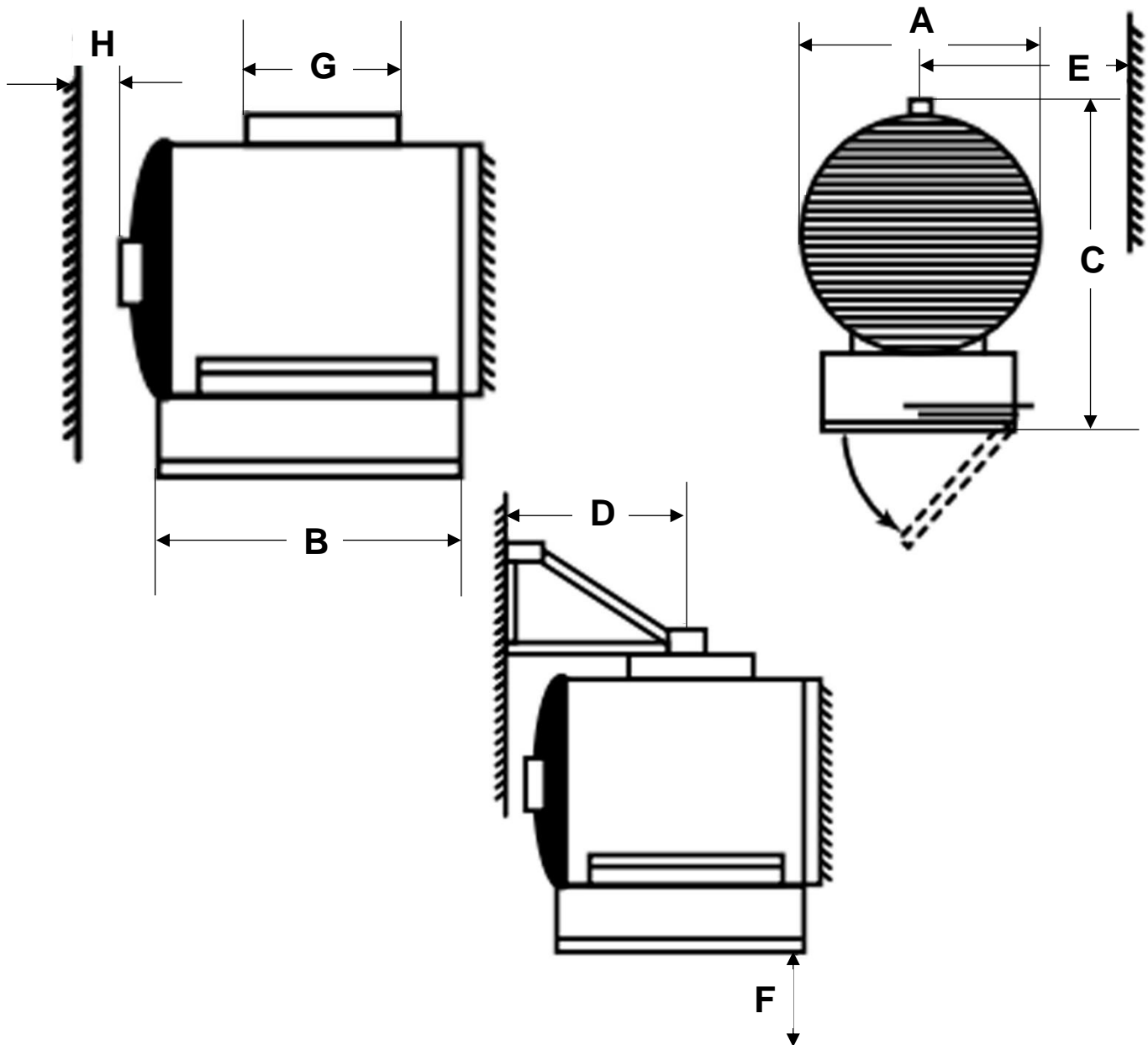



Hall of 5500 Series Washdown Fan Forced Unit Heater with bracket H5520/HMK, H5550/HMK.



ROOF OR OVERHEAD
 STRUCTURE

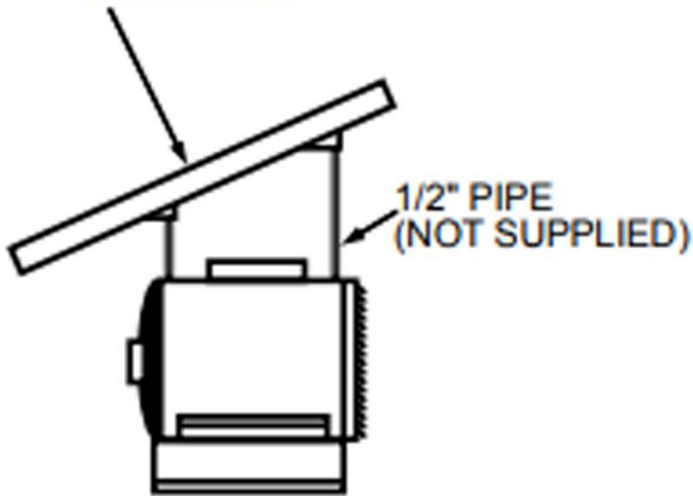

H5550

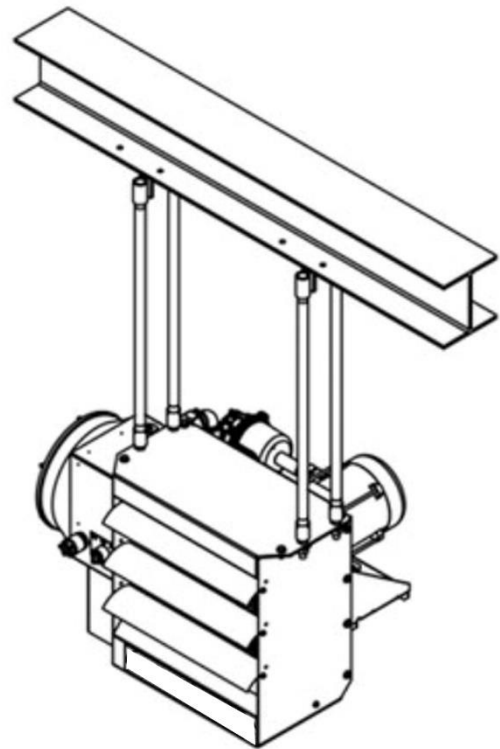

ID	Author	Description Error	Description Update	Supervisor Name
V1	Angela Romero	New Data Sheet	New Data Sheet	Jessica Lorenzo